

# Sveisbart løfteøre med fjær – APAS

- Materiale: Øye i grade 10-materiale, sveisefeste i S355J2.
- Overflatebehandling: Blålakkert øye og ubehandlet sveisefeste.

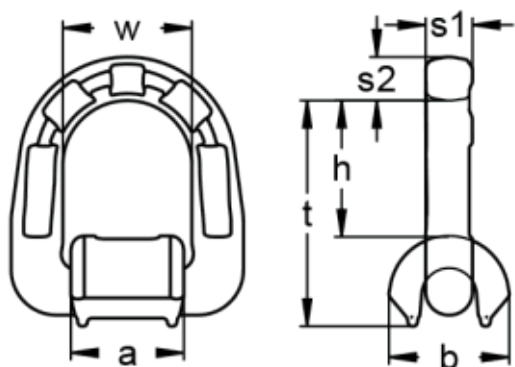

|            |        |
|------------|--------|
| Min. temp. | -20°C  |
| Max. temp. | +200°C |



Les mer om produktet her:

<https://john-dahle.no/product?number=VM-0362080>